

This fact sheet provides information about the procurement process for the turbines and generators contract.

TURBINES AND GENERATORS

BC Hydro has awarded the turbines and generators contract to Voith Hydro Inc.

The contract consists of the design, supply and installation of six vertical axis, Francis-style turbines, six generators and associated equipment.

Turbines and generators convert the power of falling water into electricity, which is then transformed and fed into the provincial electricity grid.

The performance of a turbine-generator is critical to the success of a hydroelectric project. These turbines and generators are custom designed to suit the site-specific conditions of each hydroelectric facility. This made identifying the highest value design essential to BC Hydro's efforts.

With nearly 150 workers slated to be on-site during the peak of installation in 2022, the contract is expected to create approximately 400 person-years of employment resulting in job opportunities for millwrights, electricians, pipefitters, boilermakers, and other trades. On average, 70 workers will be on site each year.

CONTRACT SCHEDULE

It is anticipated that Voith would commence design activities soon after contract award. Manufacturing of the turbines and generators will take place off-site in 2017 with installation of the equipment expected to commence in late 2019. The contractor will be on-site to complete installation and assist with commissioning until 2024.

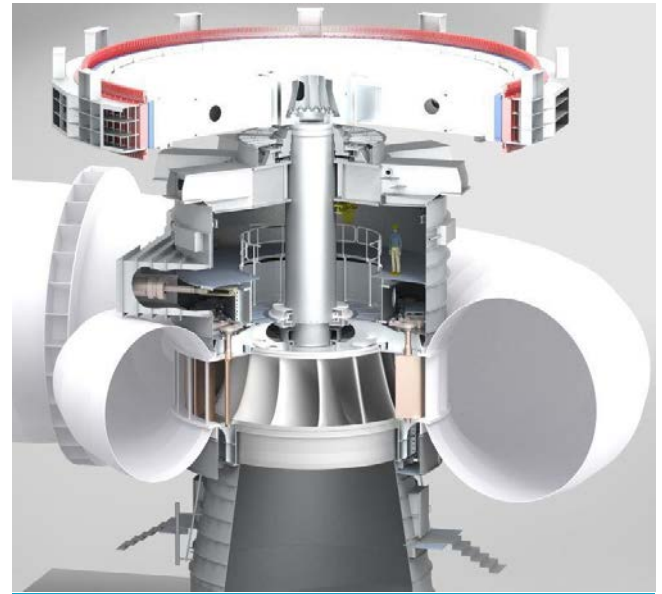

Cross-section of Site C turbine-generator unit

PROCUREMENT PROCESSES

A multi-staged procurement process was used to select the turbines and generators contractor. BC Hydro issued a Request for Qualifications in July 2012 and five responses were received. Three proponent teams were shortlisted and received the Request for Proposals in February 2013. Each proponent team undertook extensive model testing throughout 2014 and 2015.

Voith was selected as the preferred proponent in February 2016. A rigorous evaluation process, conducted in accordance with the Request for Proposals, concluded that Voith was the highest evaluated. Voith has a strong delivery record for projects of a similar size and nature and best met BC Hydro's requirements for the Site C turbine-generator contract. Voith was awarded the contract in March 2016.

Stage	Timing
RFQ Issued	July 2012
RFP Issued	February 2013
Preferred Proponent	February 2016
Contract Award	March 2016

The Site C Clean Energy Project is a hydroelectric dam and generating station under construction in northeast B.C. Once built, Site C will provide clean, reliable and cost-effective electricity for more than 100 years.